

Safety Standard Certified Resin Molding SMD Type Ceramic Capacitors for General Purpose SYW Series (Y1:250V~/400V~) 681K~103M	POE-D35-00-E-07	Ver: 07	Page: 1 / 14
---	-----------------	---------	--------------

HF

PRODUCT SPECIFICATION

PRODUCT: Safety Standard Certified Resin Molding SMD Type Ceramic Capacitors for General Purpose

TYPE: SYW SERIES (Y1:250V~/400V~)
681K~103M

CUSTOMER:

N.W.: 0.8~0.9g/pc

DOC. NO.: POE-D35-00-E-07

APPROVED BY CUSTOMER

VENDOR :

- WALSIN TECHNOLOGY CORPORATION**
566-1, KAO SHI ROAD, YANG-MEI
TAO-YUAN, TAIWAN
- PAN OVERSEAS (GUANGZHOU) ELECTRONIC CO.,LTD.**
NO.277,HONG MING ROAD,EASTERN SECTION,HUANGPU DISTRICT,
GUANG ZHOU,CHINA
- DONGGUAN WALSIN TECHNOLOGY ELECTRONICS CO., LTD.**
NO.638, MEI JING WEST ROAD,XINIUPO,ADMINISTRATIVE ZONE,DAL
ANGTOWN,DONGGUAN CITY, GUANGDONG PROVINCE

PSA

Safety Standard Certified Resin Molding SMD Type Ceramic Capacitors for General Purpose SYW Series (Y1:250V~/400V~) 681K~103M	POE-D35-00-E-07	Ver: 07	Page: 2 / 14
--	-----------------	---------	--------------

Record of change

Date	Version	Description	page
2021/9/23	00	First edition.	All
2022/7/14	01	Update 2. Mechanical Dimension Add 4. Marking add Date code comparison table Update 5.Scope 、 6. Specification and test method 7 ~10	5~13
2022/12/2	02	Update packing Q'ty	11
2023/8/30	03	Update 7 、 9	11 、 13
2024/2/6	04	Update 5.1 Safety standards approval and recognized no.	7
2024/7/3	05	5.4 Product Structure 6.2 Performance 8.2 Reflow Soldering 8.3 Wave Soldering	7 8~10 12
2024/10/8	06	6.2 Performance	8~10
2025/3/7	07	Update 2. Mechanical dimension tolerance 、 4. Marking: CQC logo 8.2 Reflow Soldering 、 8.3 Wave Soldering Add 5.3 Content of toxic and harmful substances control requirements 9 Capacitor temperature characteristic	5 6 12 7 13

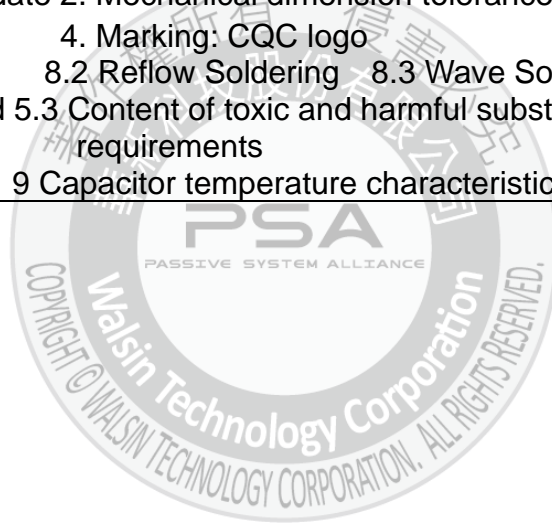

Safety Standard Certified Resin Molding SMD Type Ceramic Capacitors for General Purpose SYW Series (Y1:250V~/400V~) 681K~103M	POE-D35-00-E-07	Ver: 07	Page: 4 / 14
---	-----------------	---------	--------------

1. Part number for SAP system:

(Ex.) YP S YW 102 K P 00
(1) (2) (3) (4) (5) (6)

(1) Temperature characteristic (identified code)

CODE	Temperature characteristic	Cap. Change
YP	B (Y5P)	±10%
YU	E (Y5U)	-56% to +22%
YV	F(Y5V)	-82% to +22%

(2) SMD Type : SYW (Y1:250Vac/400Vac)

(3) Capacitance (identified by 3-figure code):ex. 681=680pF , 102=1000pF , 103=10000pF

(4) Capacitance tolerance (identified by code): K:±10%,M:±20%

(5) Special Specification Code :

Code	Description
P	Pb Solder Product

(6) Internal code: 00--Normal, other code--Special control



Safety Standard Certified Resin Molding SMD Type Ceramic Capacitors for General Purpose SYW Series (Y1:250V~/400V~/681K~103M)	POE-D35-00-E-07	Ver: 07	Page: 5 / 14
---	-----------------	---------	--------------

2. Mechanical: Encapsulation : Epoxy resin, flammability UL94 V-0

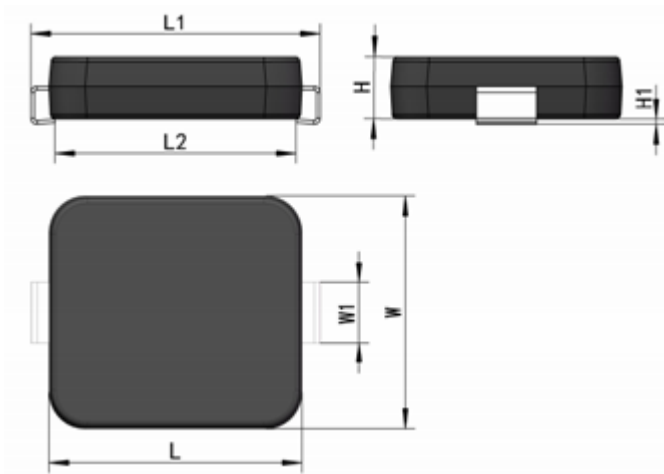





Dimension(mm)			
L	10.5±0.5	L1	12.0±0.5
W	9.6±0.5	W1	2.50±0.1
H	2.58±0.10	H1	0.15±0.05
L2	10.5±0.5		

3. Part numbering/T.C/Capacitance/ Tolerance :

SAP P/N	T.C.	Capacitance	Tolerance
YPSYW681KP00	Y5P	680 pF	±10%
YPSYW102KP00		1000 pF	
YUSYW222MP00	Y5U	2200 pF	±20%
YUSYW332MP00		3300 pF	
YUSYW472MP00		4700 pF	
YVSYW103MP00	Y5V	10000 pF	±20%

Safety Standard Certified Resin Molding SMD Type Ceramic Capacitors for General Purpose SYW Series (Y1:250V~/400V~) 681K~103M	POE-D35-00-E-07	Ver: 07	Page: 6 / 14
---	-----------------	---------	--------------

4. Marking:

1. Company Name Code(Trade mark)	UK
2. Type/Series Designation	SYW
3. Code of Dielectric	B(Y5P) / E(Y5U) / F(Y5V)
4. Nominal Capacitance	Identified by 3-Figure Code. Ex. 680pF→"681", 1000pF→"102"
5. Capacitance Tolerance	K:±10%,M:±20%
6. Class code/Rated Voltage Mark	Y1 / 250V~ ;400V~
7. Safety certification mark	UL/cUL:  ; ENEC:  ; CQC:  ; KC: 
8. Products ID (Manufactured Date code, add as needed)	Abbreviation ex.: NB210303 N:2021 year B: Sn-Pb-Ag Solder 21: Machine and batch (production line traceability) 03: March 03:date
Marking sample	
	

Date code comparison table:

code of year		code of month		code of day					
year	code	year	code	month	code	day	code	day	code
		2020	M	1	1	1	1	16	16
		2021	N	2	2	2	2	17	17
2010	A	2022	P	3	3	3	3	18	18
2011	B	2023	R	4	4	4	4	19	19
2012	C	2024	S	5	5	5	5	20	20
2013	D	2025	T	6	6	6	6	21	21
2014	E	2026	U	7	7	7	7	22	22
2015	F	2027	V	8	8	8	8	23	23
2016	H	2028	W	9	9	9	9	24	24
2017	J	2029	X	10	10	10	10	25	25
2018	K			11	11	11	11	26	26
2019	L			12	12	12	12	27	27
						13	13	28	28
						14	14	29	29
						15	15	30	30
								31	31

Safety Standard Certified Resin Molding SMD Type Ceramic Capacitors for General Purpose SYW Series (Y1:250V~/400V~) 681K~103M	POE-D35-00-E-07	Ver: 07	Page: 7 / 14
---	-----------------	---------	--------------

5. Scope:

THIS SPECIFICATION APPLIES TO CERAMIC INSULATED CAPACITORS RESIN MOLDING SMD TYPE USED IN ELECTRONIC EQUIPMENT.

5.1 Safety standards approval and recognized no.

Safety Standard	Standard No.	Subclass	w.v.	Recognized No.
UL / CUL	ANSI/UL 60384-14	Y1	250Vac/400Vac	E146544
ENEC	EN 60384-14:2013/A1:2016	Y1	250Vac/400Vac	ENEC-03633-M1
CQC	GB/T6346.14	Y1	400Vac	CQC21001310797
KC	K60384-14	Y1	250Vac	SU03127-21002

5.3 Content of toxic and harmful substances control requirements

RoHS2.0 2011/65/EU、Halogen、REACH No1907/2006

5.4 Exemption Clause

2010/571/EU 7(a) : Lead in high melting temperature type solders (i.e. lead-based alloys containing 85 % by weight or more lead)

5.5 Product Structure:

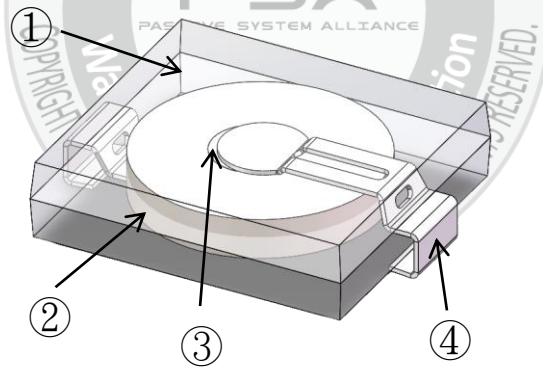

No.	Part name	Material
①	Coating	Epoxy molding compound (Conforming to UL94V-0 standard)
②	Chip	Ceramic chip
③	Solder	Sn-Pb-Ag Solder
④	Lead pin	Copper alloy
		Tin coating

Safety Standard Certified Resin Molding SMD Type Ceramic Capacitors for General Purpose SYW Series (Y1:250V~/400V~) 681K~103M	POE-D35-00-E-07	Ver: 07	Page: 8 / 14
---	-----------------	---------	--------------

6. Specification and test method:

6.1 Operating Temperature Range: -40 to +125°C

6.2 Test condition:

Test and measurement shall be made at the standard condition. (temperature 15~35°C, relative humidity 45~75% and atmospheric pressure 860~1060hpa). Unless otherwise specified herein.

If doubt occurred on the value of measurement, and measurement was requested by customer capacitors shall be measured at the reference condition. (temperature 20±2°C or 25 ± 2°C, relative humidity 60~70% and atmospheric pressure 860~1060hpa.)

6.3 Performance:

No	Items	Specification	Testing method																				
1	Appearance and dimensions	No marked defect on appearance form and dimensions. Please refer to [Part number list].	The capacitor should be inspected by naked eyes for visible evidence of defect. Dimensions should be measured with slide calipers.																				
2	Marking	To be easily legible.	The capacitor should be inspected by naked eyes.																				
3	Voltage proof	Between lead pin Body Insulation	No permanent break-down or flashover during the test period																				
			Test voltage:4000VAC Frequency:50/60Hz Duration:60 seconds Leakage current: 5mA max																				
4	Capacitance	Within specified tolerance K: ±10% M: ±20%	Temperature:25±3°C Humidity: 55±30%RH Voltage: 1.0±0.2V Frequency: 1±0.2KHZ																				
5	Dissipation Factor(D.F.)	<table border="1"> <thead> <tr> <th>Char.</th> <th>Specifications</th> </tr> </thead> <tbody> <tr> <td>B(Y5P)</td> <td rowspan="3">2.5% max.</td> </tr> <tr> <td>E(Y5U)</td> </tr> <tr> <td>F(Y5V)</td> </tr> </tbody> </table>	Char.	Specifications	B(Y5P)	2.5% max.	E(Y5U)	F(Y5V)	Temperature: 25±3°C Humidity: 55±30%RH Voltage: 1.0±0.2V Frequency: 1±0.2KHZ														
Char.	Specifications																						
B(Y5P)	2.5% max.																						
E(Y5U)																							
F(Y5V)																							
6	Temperature Characteristic	<table border="1"> <thead> <tr> <th>Char.</th> <th>Capacitance Change</th> </tr> </thead> <tbody> <tr> <td>B(Y5P)</td> <td>Within ± 10%</td> </tr> <tr> <td>E(Y5U)</td> <td>Within +22/-56%</td> </tr> <tr> <td>F(Y5V)</td> <td>Within +22/-82%</td> </tr> </tbody> </table>	Char.	Capacitance Change	B(Y5P)	Within ± 10%	E(Y5U)	Within +22/-56%	F(Y5V)	Within +22/-82%	<p>The capacitance measurement shall be made at each step specified in Table</p> <table border="1"> <thead> <tr> <th>Step</th> <th>1</th> <th>2</th> <th>3</th> <th>4</th> <th>5</th> </tr> </thead> <tbody> <tr> <td>Temp.(°C)</td> <td>+20±2</td> <td>-25±2</td> <td>+20±2</td> <td>+85±2</td> <td>+20±2</td> </tr> </tbody> </table> <p>$\Delta = (C_x - C_0) / C_0$ CX capacitor for step 2,4 C0 capacitor for step 3</p>	Step	1	2	3	4	5	Temp.(°C)	+20±2	-25±2	+20±2	+85±2	+20±2
Char.	Capacitance Change																						
B(Y5P)	Within ± 10%																						
E(Y5U)	Within +22/-56%																						
F(Y5V)	Within +22/-82%																						
Step	1	2	3	4	5																		
Temp.(°C)	+20±2	-25±2	+20±2	+85±2	+20±2																		
7	Insulation resistance	Between lead wires Body Insulation	10000MΩ MIN 10000MΩ MIN	The insulation resistance shall be measured with DC500±50V within 60±5s of charging. The voltage should be applied to the capacitor through a resistor of 1MΩ.																			
8	Solderability	Good tin coating (tin rate above 90%), within 3 seconds of convergence..	Immerse the capacitor in the solution of ethanol (JIS K 8101) and rosin (JIS K 5902) (25% rosin in weight proportion). (Reference) Bath temperature: 245±10°C Immersion time: 2±0.5seconds Depth of immersion(from the seating plane or component body): Capacitors below 2 ⁰ -0.5mm,using a thermal insulating screen of 1.5±0.5mm thickness. 1.5±0.5mm																				

Safety Standard Certified Resin Molding SMD Type Ceramic Capacitors for General Purpose SYW Series (Y1:250V~/400V~) 681K~103M	POE-D35-00-E-07	Ver: 07	Page: 9 / 14
--	-----------------	---------	--------------

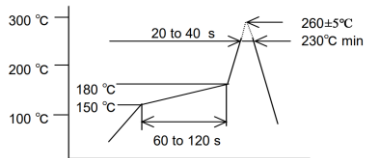
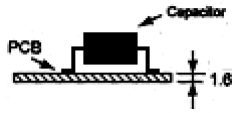
No	Items	Specification	Testing method	
9	Soldering Heat Resistance	Appearance	Reflow(peak)Solder temperature : 260±5℃ Solder zone : 230℃ min. 20-40s Pre-treatment 	
		I.R.		refer item 7
		voltage proof		refer item 3
		Dissipation factor		Y5P:≤2.5% Y5U:≤2.5% Y5V:≤2.5%
		Capacitance Change		B(Y5P) : Within ±10% E(Y5U),F(Y5V) : Within ±20%
10	Vibration	Appearance	Frequency ranges: 10→55→10Hz Swing:1.5mm, The total duration shall be 6 hours. Duration of exposure at X,Y,Z : 2hours 	
				Y5P: ±10% Y5U: ±15% Y5V: ±15% DF ≤2.5%
11	Temperature cycle	Appearance	Pre-treatment : The capacitor should be stored at 125 ± 3℃ for 1 hour and subjected to AC4000V (r.m.s.) for 60 seconds. Then, it should be left at room temperature for 24 ± 2 hours before initial measurement Upper category temperature : +125±3℃ Lower category temperature : -40±3℃ Number of cycles :5 Duration of exposure at the temperature limits : 30minutes Capacitor shall be placed at 25±3℃ for 24±2h before initial measurements.	
		voltage proof		refer item 3
		Capacitance		Y5P: ±10% Y5U/Y5V: ±20%
		dissipation factor		Y5P/Y5U/Y5V: ≤2.5%
		Insulation resistance		≥3000MΩ
12	Impulse voltage	No permanent breakdown or flashover during the test period	Peak impulse voltage: 8.0KV Impulses distance : > 10seconds Impulses times:24	
		If any three successive impulses are shown by the oscilloscope monitor to have had a waveform indicating that no self-healing breakdowns or flashovers have taken place in the capacitor, then no further impulses shall be applied and the capacitor shall be counted as conforming.		
		If all 24 impulses have been applied to the capacitor and 3 or more of them are of a waveform indicating that no self-healing breakdowns or flashovers have occurred, then the capacitor shall be counted as conforming.		
		If less than three impulses are of the required waveform, then the capacitor shall be counted as a nonconforming item.		

Safety Standard Certified Resin Molding SMD Type Ceramic Capacitors for General Purpose SYW Series (Y1:250V~/400V~/681K~103M)	POE-D35-00-E-07	Ver: 07	Page: 10 / 14
--	-----------------	---------	---------------

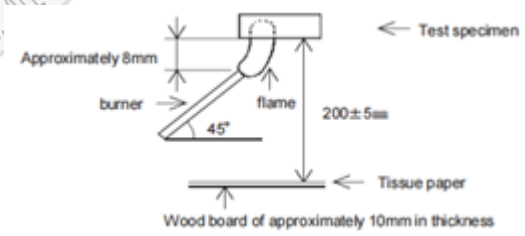
No	Items	Specification	Testing method
13	Endurance	Appearance	No marked defect.
		Capacitance Change	$\Delta=(C_x-C_0)/C_0$ Y5P: $\pm 10\%$ Y5U: $\pm 15\%$ Y5V: $\pm 15\%$
		I.R.	$\geq 3000M\Omega$
		voltage proof	Per Item 3
		Dissipation factor	Y5P: $\leq 5\%$ Y5U: $\leq 5\%$ Y5V: $\leq 5\%$
<p>Pre-treatment: The capacitor should be stored at $125 \pm 3^\circ\text{C}$ for 1 hour and subjected to AC4000V (r.m.s.) for 60 seconds. Then, it should be left at room temperature for 24 ± 2 hours before initial measurement.</p> <p>Test temperature: $125 \pm 3^\circ\text{C}$</p> <p>Duration: 1000+24/-0hours</p> <p>Test voltage: 680VAC (1.7 U_R), except that once every hour the voltage shall be increased to 1000v r.m.s. for 0.1s. 680 VAC (1.7 U_R)</p> <p>Each of these voltage shall be applied to each capacitor individually through a resistor of $47\Omega \pm 5\%$.</p> <p>Capacitor shall be placed at $25 \pm 3^\circ\text{C}$ for 24 ± 2 hours before measurements.</p>			
14	Damp heat steady state	Appearance	No marked defect.
		Capacitance Change	$\Delta=(C_x-C_0)/C_0$ Y5P: $\pm 10\%$ Y5U/Y5V: $\pm 15\%$
		I.R.	$\geq 3000M\Omega$
		voltage proof	Per Item 3
		Dissipation factor	Y5P: $\leq 5\%$ Y5U: $\leq 5\%$ Y5V: $\leq 5\%$
<p>Pre-treatment</p> <p>The capacitor should be stored at $125 \pm 3^\circ\text{C}$ for 1 hour and subjected to AC4000V (r.m.s.) for 60 seconds. Then, it should be left at room temperature for 24 ± 2 hours before initial measurement</p> <p>test temperature: $40 \pm 2^\circ\text{C}$</p> <p>humidity: $95 \pm 3\%RH$</p> <p>duration: 500+12/-0hours</p> <p>voltage : Apply $U_R(400V)$ to half of the samples and no voltage to the other half.</p> <p>capacitor shall be placed at $25 \pm 3^\circ\text{C}$ for 24 ± 2 hours before measurements</p>			
15	Passive flammability	<p>The burning time should not be exceeded the time 10s.</p> <p>The tissue paper should not ignite</p>	<p>The capacitor under test shall be held in the flame in the position which best promotes burning. Each specimen shall only be exposed once to the flame. Time of exposure to flame : 20 s</p> <p>Length of flame : $12 \pm 1\text{mm}$</p> <p>Gas burner : Length 35mm min.</p> <p>Inside dia : $0.5 \pm 0.1\text{mm}$</p> <p>Outside dia : 0.9mm max. Gas : Butane gas purity 95% min.</p> 
16	Component solvent Resistance	No visible damage. Performance according Item 3~7	<p>Solvent to be used: $30 \pm 5\%$ alcohol and $70 \pm 5\%$ fluxional compound</p> <p>Solvent temperature: $23 \pm 5^\circ\text{C}$</p> <p>The capacitor shall be immersed in solvent for 5 ± 0.5 minutes</p> <p>Recovery time: 8hours</p>
17	Solvent resistance of the marking	The marking shall be legible	<p>Solvent to be used: $30 \pm 5\%$ alcohol and $70 \pm 5\%$ fluxional compound</p> <p>Solvent temperature: $23 \pm 5^\circ\text{C}$</p> <p>The capacitor shall be immersed in solvent for 5 ± 0.5 seconds and its mark shall be wiped with plectet for 10times.</p>

Safety Standard Certified Resin Molding SMD Type Ceramic Capacitors for General Purpose SYW Series (Y1:250V~/400V~/681K~103M)	POE-D35-00-E-07	Ver: 07	Page: 11 / 14
---	-----------------	---------	---------------

7.Packing Description :

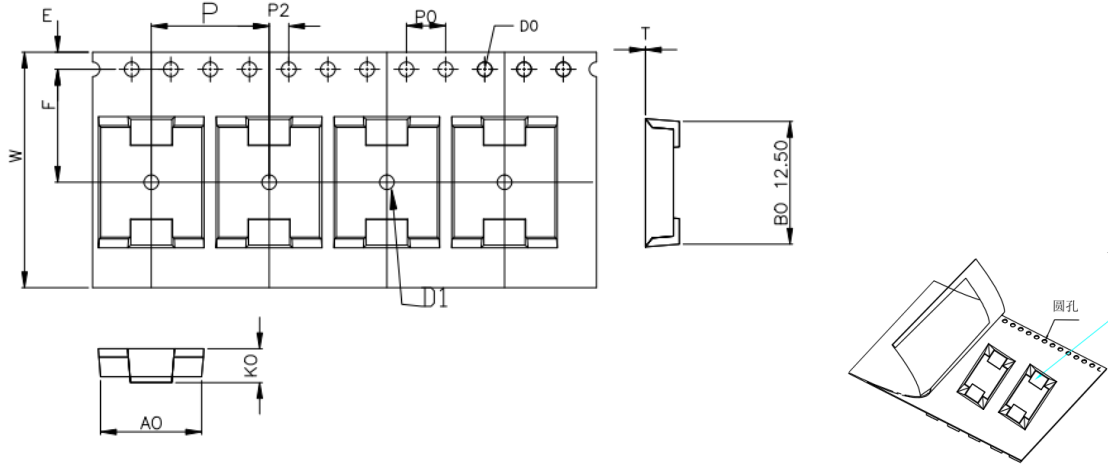

ITEM	W	E	F	P	P0	P2	D0	D1	T	B0	A0	K0
DIM	24.00 ^{+0.30} _{-0.30}	1.75 ^{+0.10} _{-0.10}	11.50 ^{+0.10} _{-0.10}	12.00 ^{+0.10} _{-0.10}	4.00 ^{+0.10} _{-0.10}	2.00 ^{+0.10} _{-0.10}	φ1.50 ^{+0.10} ₋₀	φ1.50 ^{+0.10} ₋₀	0.3 ^{+0.05} _{-0.05}	12.50 ^{+0.10} _{-0.10}	10.00 ^{+0.10} _{-0.10}	3.45 ^{+0.10} _{-0.10}

Reel Drawing

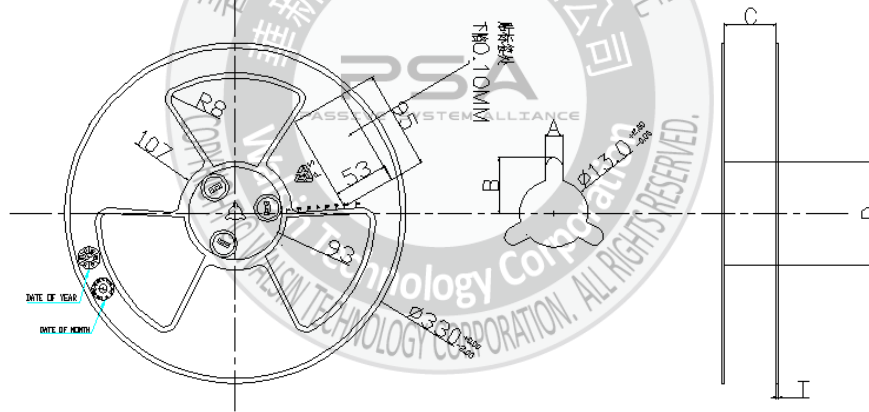

SPEC	A±0.3	B±0.5	C ^{+0.5} _{-0.0}	D±0.5	T±0.2
24	2.3	10.75	24.4	Ø97	2.2

Q'ty/reel	reel size
1500pcs	13inch

Safety Standard Certified Resin Molding SMD Type Ceramic Capacitors for General Purpose SYW Series (Y1:250V~/400V~/681K~103M)	POE-D35-00-E-07	Ver: 07	Page: 12 / 14
---	-----------------	---------	---------------

8. Soldering Recommendation:

8.1 Soldering Land Pattern Size:

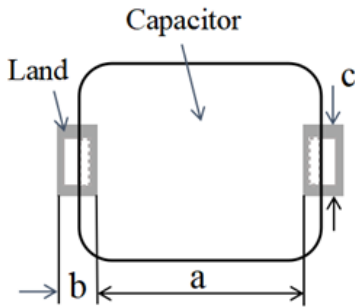

Package Dimension	a(mm)	b(mm)	c(mm)
10.5×9.6	10.0min	2.2±0.1	3.6±0.1

8.2 Reflow Soldering

When soldering capacitor, it should be performed in following conditions. and the continuous welding times should not exceed three times. Soldering temperature : 260±5°C.

Soldering time : 120s max.

Preheating temperature: 150°C max.

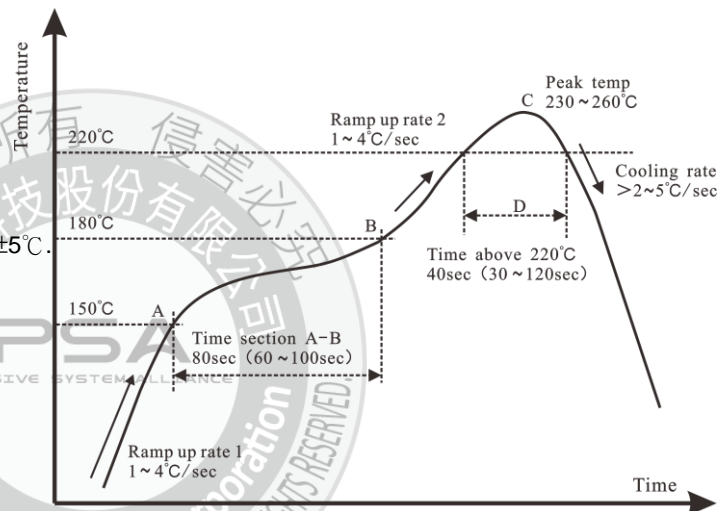

8.3 Wave Soldering

When soldering capacitor, it should be performed in following conditions. and the continuous welding times should not exceed three times. Soldering temperature : 260±5°C

Soldering time : 10s max.

Preheating temperature: 100°C max.

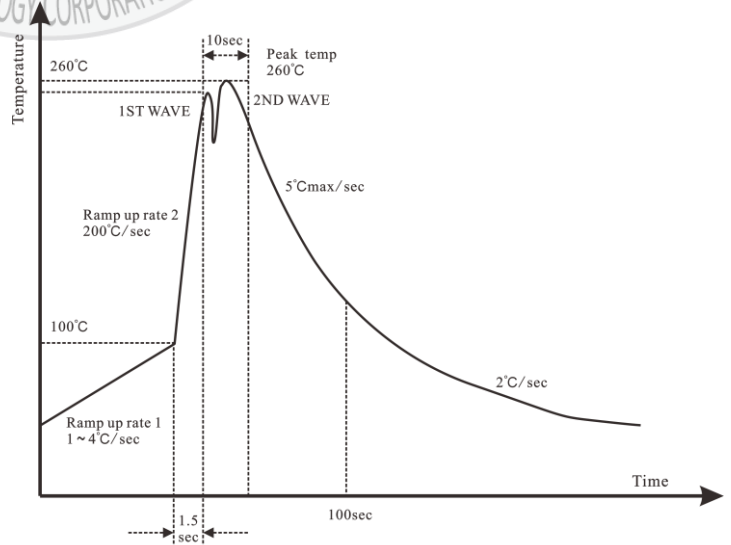

Safety Standard Certified Resin Molding SMD Type Ceramic Capacitors for General Purpose SYW Series (Y1:250V~/400V~) 681K~103M	POE-D35-00-E-07	Ver: 07	Page: 13 / 14
---	-----------------	---------	---------------

8.4 Soldering Iron

When soldering this product to a PCB/PWB, do not exceed the solder heat resistance specification of the capacitor. Subjecting this product to excessive heating could melt the internal junction solder and may result in thermal shocks that can crack the ceramic element.

When soldering capacitor with a soldering iron, it should be performed in following conditions.

Temperature of iron-tip : 400°C max.

Soldering iron wattage : 50W max.

Soldering time : 5s max.

9. Capacitor temperature characteristic

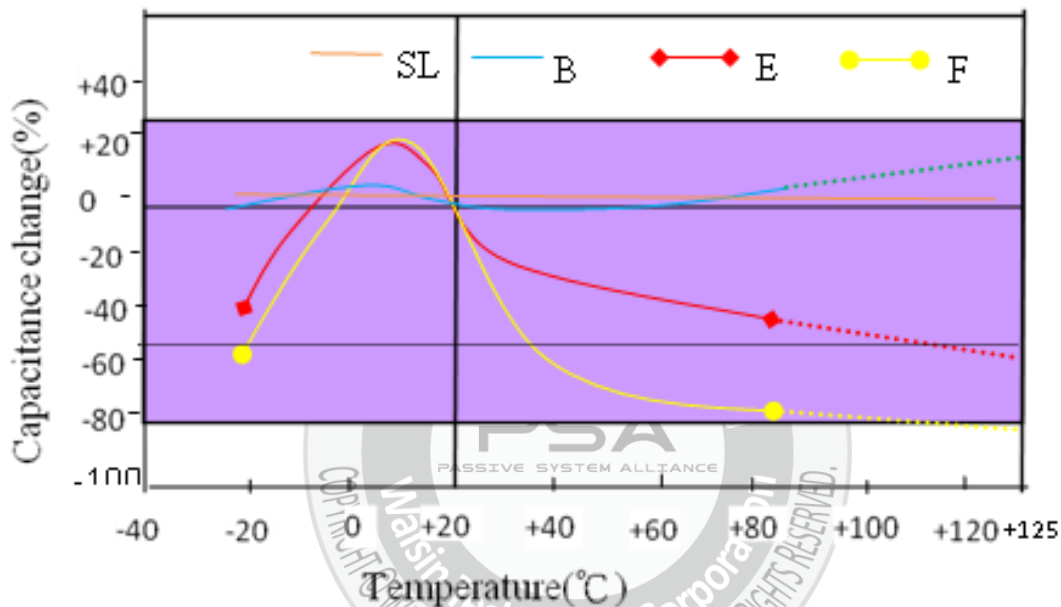

10. Storage conditions

10.1 The insulating Epoxy molded capacitors does not form a perfect seal; therefore, do not use or store capacitors in a corrosive atmosphere, especially where chloride gas, sulfide gas, acid, alkali, salt or the like are present. And avoid exposure to moisture. So, in order to avoid the absorption of moisture, capacitors are packed in moisture-proof envelope.

10.2 Store the capacitors in the following conditions at all times, and use within 12 months after delivered.

Temperature: 10 ~ 30°C

Humidity: 60% max.

10.3 Solder the enclosed capacitors within 168 hours after opening the moisture-proof package. After opening, store the capacitors in moisture-proof package with a desiccant and HIC card and keep the above condition.

10.4 In case the storage period has been exceeded 12 months or the indicator color of a enclosed HIC card has changed when the package has been opened, perform baking (60°C x 168hr) before soldering.

Safety Standard Certified Resin Molding SMD Type Ceramic Capacitors for General Purpose SYW Series (Y1:250V~/400V~) 681K~103M	POE-D35-00-E-07	Ver: 07	Page: 14 / 14
---	-----------------	---------	---------------

11 Application note

11.1 Attention is drawn to the fact that repetition of the voltage proof test by the user may damage the capacitor.

11.2 Capacitors mounted on a printed circuit board (PCB) requirements of PCB board welding disc required and capacitor pin paste solder joint agreement, the opposite may cause the capacitor and the PCB board to bad welding and capacitor tube deform the feet or body destruction and damage the capacitor.

11.3 Avoid any compressive, tensile or flexural stress.

11.4 Please consult us first if you wish to embed the capacitor in plastic resins.

11.5 Do not move the capacitor after it has been soldered to the board.

11.6 Do not pick up the PC board by the soldered capacitor.

